

Suppliers' Information Note

For The Openreach Network

OPENREACH BACKHAUL EXTENSION SERVICES 10 (BES 10)

Service & Interface Description

Each SIN is the copyright of British Telecommunications plc. Reproduction of the SIN is permitted only in its entirety, to disseminate information on the Openreach Network within your organisation. You must not edit or amend any SIN or reproduce extracts. You must not remove Openreach trademarks, notices, headings or copyright markings.

This document does not form a part of any contract with Openreach customers or suppliers.

Users of this document should not rely solely on the information in this document, but should carry out their own tests to satisfy themselves that terminal equipment will work with the Openreach network.

Openreach reserves the right to amend or replace any or all of the information in this document.

Openreach shall have no liability in contract, tort or otherwise for any loss or damage, howsoever arising from use of, or reliance upon, the information in this document by any person.

Due to technological limitations a very small percentage of customer interfaces may not comply with some of the individual characteristics which may be defined in this document.

Publication of this Suppliers' Information Note does not give or imply any licence to any intellectual property rights belonging to British Telecommunications plc or others. It is your sole responsibility to obtain any licences, permissions or consents which may be necessary if you choose to act on the information supplied in the SIN.

This SIN is available in Portable Document Format (pdf) from:
<https://www.openreach.co.uk/orpg/home/helpandsupport/sins/sins.do>

Enquiries relating to this document should be directed to: orsinsfa@openreach.co.uk

CONTENTS

1	INTRODUCTION.....	3
2	SERVICE OUTLINE & OPTIONS	3
2.1	GENERAL.....	3
2.2	BES 10 FEATURES	5
3	CUSTOMER INTERFACE.....	5
3.1	GENERAL.....	5
3.2	BES 10 INTERFACE – RJ45 INTERFACE OPTION	5
4	POWER SUPPLY REQUIREMENTS	6
4.1	GENERAL.....	6
4.2	INSTALLATION AND TESTING.....	6
4.3	AC POWER CONNECTION	6
4.4	DC POWER CONNECTION	7
4.5	ADDITIONAL DETAILS	7
5	FURTHER INFORMATION	7
6	REFERENCES.....	9
7	ABBREVIATIONS	9
8	DOCUMENT HISTORY	10

FIGURES

Figure 1. <i>BES 10 Service Configuration</i>	4
Figure 2. <i>BES 10 NTE - RJ45 Connector Pin Out Connections</i>	6

TABLES

Table 1. <i>Table of BES 10 Services & Principle Features</i>	4
---	---

1 Introduction

This Suppliers Information Note (SIN) describes the interface provided with Openreach Backhaul Extension Services 10 (BES 10). Also provided is some additional general information on BES and on some of the physical aspects of the NTEs currently being deployed for new customer orders.

Backhaul Extension Services (BES) are high speed, point-to-point data circuits that are permanently connected and available 24 hours a day, 365 days per year. They provide a secure link between a Communication Provider's network located in a BT Exchange, using Co-location, Netlocate or BT Locate accommodation and a Communications Provider's network located in their own accommodation or the BT exchange options of Co-location, Netlocate, BT Locate and also a BT Core Node.

From a technical perspective, BES is similar to LAN / SAN Extension Services (formerly known as Short Haul Data Services - SHDS), a retail product marketed by BT Global Services. However, unlike LAN / SAN Extension Services, this product cannot be used to link to any third party customer sites.

Any specific technology mentioned in this document is current as of today, however it may be subject to change in the future. Should the specification of the interface be changed, this will be notified by a new issue of this SIN. BT reserves the right to adapt technology to deliver BES as new developments are made. All services are delivered over an uncontended transmission path.

SPECIAL NOTICE

Openreach originally notified Industry that this Product will longer be supported as from 1 April 2018

Please refer to briefing GEN061/14 (www.openreach.co.uk)

Support has been extended until March 31st 2021. As of April 1st 2020 this support is on a reasonable endeavours basis.

Please refer to ETH014/19 WES/WEES/BES (up to and including 1Gbps) withdrawal of service for end of life notification details.

Please refer to ETH011/20 WES/WEES/BES (up to and including 1Gbps) changes to the service level agreement for change of support notification.

2 Service Outline & Options

2.1 General

Openreach Backhaul Extension Services allow a user to interconnect Ethernet – CSMA / CD Local Area Network segments conforming to ISO / IEC 8802-3 (IEEE 802.3)^[1] standards.

The BES 10 service operates at a data transmission rate of 10 Mbit/s between NTEs, and offers a number of options of transmission distance range between a Communications Provider's (CP) equipment at an unbundled MDF site and a site within an CPs own network.

Depending upon the service chosen, the appropriate type of Network Terminating Equipment (NTE) will be provided at both ends of the uncontended transmission infrastructure, terminated within the CPs premises and Licensee's MDF site.

The uncontended transmission path is routed via the BT network and is cabled directly between the Licensee’s MDF equipment and the CPs network at their site.

BT does not offer any remote management on BES 10.

Backhaul Extension Services (BES)	10	
Principal Ethernet Network Service Characteristic:	Bridge	
NTE Interface Option:	10BaseT (RJ45)	
Maximum allowable Radial Distances between Customer Premises / Sites:	25 km	<i>See Note 1</i>
Maximum Route & Range Distances between Customer Premises / Sites:	40 km	<i>See Note 2</i>
Half / Full Duplex Operation:	Full or Half Duplex	

Table 1. Table of BES 10 Services & Principle Features

Note 1. This is the direct distance “as the crow flies” between the two site locations.

Note 2. The maximum Route distance is the limiting factor of either the physical transmission limit between NTEs over the provided interconnecting transmission infrastructure, or alternatively the maximum range that the service may be extended to due to other technical considerations (e.g. optical loss).

A schematic of the BES 10 service arrangement is shown in Figure 1.

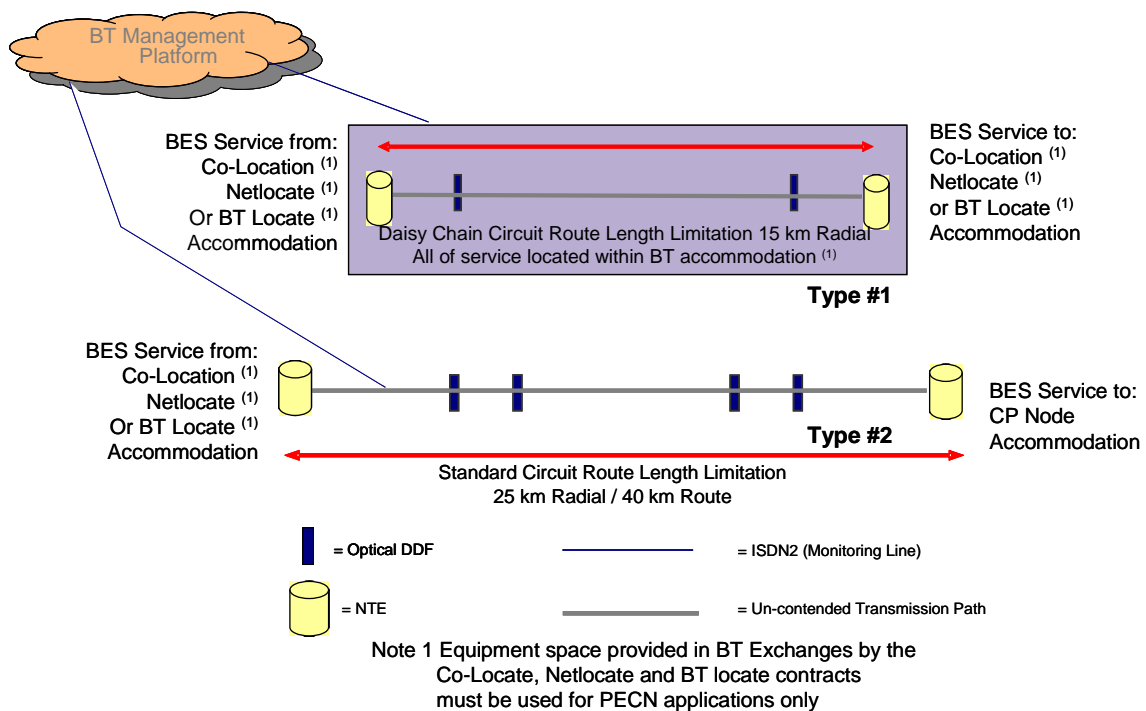

Figure 1. BES 10 Service Configuration

Note 3. Figure 1 depicts two separate circuit scenarios, not a combined service. The upper scenario (Type #1, NTE to NTE) represents a BES circuit with where both ends have a common serving exchange. The lower scenario (Type #2, NTE to NTE via a serving exchange) represents a BES circuit which ends are served from different exchanges

Note 4. The service cannot be purchased as a point-to-point circuit directly connected between the CP and a 3rd party customer site.

It is anticipated that CPs will use these services for the interconnection of their networks.

BES 10 service additionally offers the Bridge feature; automatically learning and filtering the transmission of traffic destined for the local end based on MAC addresses. See Section 2.2.

The overall design of the customer network, including the BES circuit, will need to be within the normal operating ranges and parameters of Ethernet to operate satisfactorily.

Where the service offers a duplex option, both NTEs should be configured for the same mode of operation (i.e. either Half or Full Duplex).

2.2 BES 10 Features

This service includes the IEEE 802.1d^[2] Bridging functionality, which allows for the learning and filtering of traffic packets destined for those hosts connected at the local end. Packets destined for these local end (MAC) addresses will not be forwarded across the transmission path to the distant end after these (MAC) addresses have been learnt, and until the system's Cache memory has been refreshed after a host has been removed.

The Full Duplex option is in accordance with IEEE 802.3x^[3]. The NTE is configured by BT to the customers requirements of either Half or Full Duplex.

The BES 10 NTE is capable of transmitting frame sizes from 64 bytes to a maximum of 1548 bytes. This is to maintain compatibility with a number of frame tagging formats, in particular VLAN tagging as specified in IEEE 802.1q^[4] with 1522 byte frame size.

Note. The definition of frame lengths includes the 4 byte CRC but does not include any preamble.

Where packet-loss sensitive applications such as Voice over IP (VoIP) are carried over Half-Duplex network arrangements, it is recommended that the throughput should not exceed 40%, to prevent any packet loss due to collisions. This is a limitation of the Ethernet protocol in Half-duplex mode and not of the BES NTE.

3 Customer Interface

3.1 General

The interface requirements are specified in ISO/IEC 8802-3 (IEEE 802.3)^[1].

Attention is drawn to the Intellectual Property Rights (IPRs) set out in the preface of this agreed international standard. It is the responsibility of the supplier of CPs CPE equipment to ensure that they have the necessary rights from the owner of the IPR. The IPR owner has stated that they are willing to negotiate licences under reasonable and non-discriminatory terms and conditions with applicants throughout the world.

The interface supports Ethernet, operating at 10 Mbit/s.

3.2 BES 10 Interface – RJ45 Interface Option

The interface requirements are specified in the 10BaseT Clause 14 of ISO/IEC 8802.3 (IEEE 803.2)^[1].

The Interface connector on the NTE consists of a RJ-45 type socket.

The CP provides the Category 5 connecting cables between the NTE and their equipment, and these should be no longer than 100 metres.

The connector pin outs are shown for information.

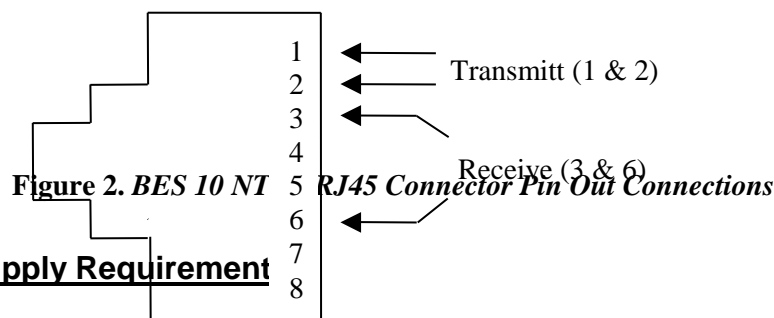

4 Power Supply Requirement

4.1 General

By placing a order with Openreach the customer has accepted the conditions placed by Openreach. In relation to powering of equipment, the customer must comply with the requirements of BS7671 and the details giving within the 'DC Power Planning and Installation Guide for WES-BES Products' document.

The Openreach BES 10 NTE is locally powered and offers AC or DC power options. The CP will be required to provide either 50Hz AC mains supply in the form of standard 13 Amp power socket(s), or dual -50v DC power distributions and Earth connections, with all wiring colour schemes conforming to BS 7671 (IEE Wiring Regulations). It will be the customer's responsibility to ensure that the power supply is fused and safe for Openreach to use. These should be in close proximity to the NTE installation location.

4.2 Installation and Testing

In addition to the NTE and Chassis powering requirements below, a spare 50Hz AC mains supply 13amp socket should also be provided in close proximity to the NTEs, to power BT test equipment during both initial commissioning and subsequent maintenance support activities.

4.3 AC Power Connection

AC power connection between Openreach equipment and the power socket will be made using a standard IEC320 C13-14 power lead fitted with standard 13A plugs. The NTE itself has dual power supply units.

Orders placed from 3rd April 2008, new NGN compatible NTE may be supplied for unmanaged services where both ends of the circuit terminate with stand-alone 1U high NTE. These NTE have

dual power supply units and require two 13A power sockets. This has the benefit of allowing for separate power supplies to enhancing resilience.

- **For most installations:**

This will require two mains connections for each NTE provided, and the consumption of the Openreach NTE and power unit chassis in this unmanaged service arrangement will be no more than 21 Watts per NTE.

- **For larger installations (at Openreach discretion):**

At Openreach's discretion, where a large number of systems of one type are being deployed, a 16-slot NTE chassis version may be deployed. This will require two mains connections for each 16-slot chassis provided. The consumption with a maximum number of 16 service cards provided will be no more than 200 Watts per chassis.

4.4 DC Power Connection

The DC In-Line (Molex) connector is specified as the standard method of connecting DC power by Openreach, and represents the "Demarcation Point" between Openreach and the customer. At their site, the customer is required to provide suitable power and earth connection to, and be responsible for the supply, wiring and labelling to the demarcation point. Openreach will not supply or install the DC distribution system as part of the standard Ethernet installation.

- **Customer provided wiring up to the Openreach specified In-Line connector.**

Wiring, MCB isolation or fuse (i.e. C Type MCB or Cartage Fuse), must be provided by the customer, up to and including the DC in-line connector, as per Openreach's requirements stated within the 'DC Power Planning and Installation Guide for WES-BES Products' document with respect to:

- (i) Correctly rated MCB/Fuse,
- (ii) Correct labelling of wiring and MCB/fuse positions compliant with BS 7671,
- (iii) Correct size of cable for required voltage drop at required maximum current,
- (iv) Separately fused isolatable A & B power supplies, as detailed in the 'DC Power Planning and Installation Guide for WES-BES Products' document.

The in-line connector has a maximum current handling capability of 6A, and is not to be used for equipment requiring greater than a 6A supply (such as the Nortel Optera 5200 equipment, which require 20A feeds).

4.5 Additional Details

For further details on the provision of DC Power, see the '[DC Power Planning and Installation Guide for WES-BES Products](#)' available on the Openreach Ethernet website at.

If there is a conflict between DC power information contained in the 'DC Power Planning and Installation Guide for WES-BES Products' and the SIN document, the order of precedence shall be as follows:

- (a) DC Power Planning and Installation Guide for WES-BES Products 0
- (b) SIN

5 Further Information

For enquiries concerning connection availability between particular sites and for further information on the BES 10 service please contact your company's Openreach Customer Business Manager, or see

<https://www.openreach.co.uk/org/home/products/ethernetservices/backhaulextensionservices/bes.d>
[o](#)

6 References

Ref:	Standard / Requirement:	Title / Description:	Date:
[1]	ISO/IEC 8802-3	ISO/IEC edition of ANSI/IEEE 802.3 CSMA/CD Ethernet Standard. (Clauses within the ISO document correspond to clauses within IEEE 802.3 document)	-
[2]	IEEE 802.1d	IEEE Recommendations for Bridging: Learning and Forwarding	-
[3]	IEEE 802.3x	IEEE Recommendations for Local and Metropolitan Area Networks: Specification for 802.3 Full Duplex	1997
[4]	IEEE 802.1q	IEEE Recommendations for Virtual LANs	1998

For further information or copies of referenced sources, please see document sources at:

<https://www.openreach.co.uk/orpg/home/helpandsupport/sins/sins.do>

7 Abbreviations

ANSI	American National Standards Institute
BES	Backhaul Extension Services
CP	Communications Provider (Providers of Electronic Communications Services)
CPE	Customer Premises Equipment
CRC	Cyclic Redundancy Check
CSMA/CD	Carrier Sense Multiple Access with Collision Detection {Ethernet}
DDF	Digital Distribution Frame
DSLAM	Digital Subscriber Line Access Multiplexer
IEC	International Electrotechnical Commission
IEEE	Institute of Electrical and Electronics Engineers {USA}
IP	Internet Protocol
IPR	Intellectual Property Rights
ISO	International Standards Organisation
LAN	Local Area Network
LLU(O)	Local Loop Unbundling (Operator)
MAC	Media Access Control (& Hardware Device Address)
MCB	Mini Circuit Breaker
MDF	Main Distribution Frame
NTE	Network Terminating Equipment
PoC	Point of Connect
SAN	Storage Area Network
SHDS	Short Haul Data Service
SIN	Suppliers' Information Note
VLAN	Virtual Local Area Network
VoIP	Voice over Internet Protocol

8 Document History

Issue	Date	Notes
Issue 1.0	27 May 2005	First Issue
Issue 1.1	29 Sept 2006	Service description updated to be Equivalence of Input compliant, block schematic changed.
Issue 1.2	29 Oct 2007	Service description amended in accordance with updated DC power guidance
Issue 1.3	4 March 2008	Service description amended in accordance with updated AC power guidance
Issue 1.4	February 2011	Amended to notify no new service will be made available
Issue 1.5	March 2013	Amended to notify withdrawal of WES, WEES and BES modify scenarios.
Issue 1.6	April 2015	Amended to notify that this Product will longer be supported as from 1 April 2018 In section 5, Updated link for further information Change SINet site references from http://www.sinet.bt.com to http://www.btplc.com/sinet/
Issue 1.7	June 2020	Amended to notify changes to the end of life date and service level agreement.
Issue 1.7	June 2021	Annual Review – no changes made – issue number therefore remains the same

--- END OF DOCUMENT ---