

**FOR DETAILED TERMS AND CONDITIONS REFER TO THE SUB LOOP CIRCUIT ACCESS  
AGREEMENT**

**PRODUCT DESCRIPTION**

*Sub-Loop Unbundling (SLU)*

This document contains a non-technical description of Sub-Loop Unbundling. Also included is an outline description of line sharing with sub-loop unbundling.

**CONTENTS**

- 1. Outline of Product**
- 2. General Description for SLU**
- 3. Information Provision for SLU**
- 4. Line Sharing with SLU**
- 5. MPF (Classic)**
- 6. Supporting Processes – Provision**
- 7. Supporting Processes - Repair**
- 8. Service Availability**

**FOR DETAILED TERMS AND CONDITIONS REFER TO THE SUB LOOP CIRCUIT ACCESS AGREEMENT**

**1. OUTLINE OF PRODUCT**

- 1.1 This paper is a description of OPENREACH's Sub Loop Unbundling products. These products have been developed to meet OPENREACH's obligations under the EU Regulation of 5 December 2000 on unbundled access to the local loop. Sub-loop unbundling (SLU) means providing an Operator with access to a partial local loop connecting the network termination point at the end customer's premises to a concentration point or a specified intermediate access point in the local network.
- 1.2 A Sub Loop Unbundling circuit consists of a circuit offering a 2 wire point to point metallic transmission path between a served end-user premise and SLU Operators Equipment connected by copper wire tie cables to a Sub Loop Connection Point within the OPENREACH Access network. The circuit provided will allow an Operator to deploy relevant equipment in order to provide telecommunications services to the end-user. Electronics deployed by the Operator must conform to the BT Access Network Frequency Plan referred to in paragraph 2.8 below. OPENREACH will be responsible for the provision, maintenance and repair of the Sub Loop Unbundling circuit. The product will include both SMPF and MPF options.
- 1.3 Sub Loop Unbundling circuits are made up of elements of a number of supporting products. These products are :-
- Sub Loop Access Tie Cable Product: The provision and repair of a transmission link between a OPENREACH SLCP and the point of handover to the SLU Operator.
  - Sub Loop CP Upgrade: The preparation of a SLCP in order for it to provide access to a Sub Loop Tie cable.
  - SLU handover joint box at the SLU Operators equipment site
- 1.4 The Sub-Loop Unbundling service will be offered to those Operators entitled to request it under the EU regulation.
- 1.5 Deployment of ADSL and VDSL electronics is particularly sensitive to cross talk. In order to ensure that all Operators have an equal opportunity to deploy to a given location, it will be necessary to stipulate certain characteristics of the Sub Loop Tie Cable [1].
- 1.6 A pre-requisite of the SLU line-sharing product will be the previous availability of the SLU Connection Point and Sub-Loop Tie Cables provided to the Operator under terms and conditions documented in the OPENREACH Sub Loop Circuit Access Agreement and splitters provided by the Operator at the appropriate Operator Site and at the end user premises. The splitters must comply with the specification described in the line sharing splitter specification [2].

**FOR DETAILED TERMS AND CONDITIONS REFER TO THE SUB LOOP CIRCUIT ACCESS AGREEMENT**

**LLU SUB-UNBUNDLING SCHEMATIC**

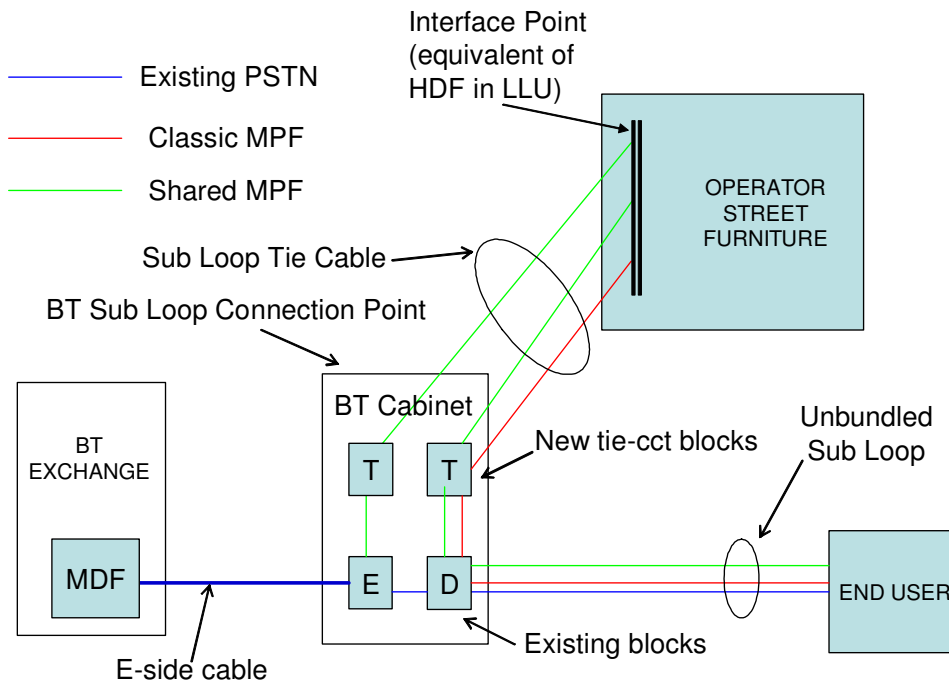

**2. GENERAL DESCRIPTION FOR SLU**

- 2.1 SLU will be implemented on a dedicated point to point metallic path between a specific end-user's premise and SLU Operators Equipment connected via a Sub Loop Connection Point (SLCP) in the OPENREACH Access Network.
- 2.2 From the relevant OPENREACH SLCP, the Operator will be provided with a Sub Loop Tie Cable compliant to reference [1] to the interface point within the SLU Operators equipment enclosure, the role of the interface point being similar to that of the Handover Distribution Frame under LLU.
- 2.3 To avoid interference between Operators accessing the same SLCP, all Sub Loop Tie Cables must comply with the Specification for the Sub Loop Tie Cable [1].  
If the Operator uses VDSL, then tie-cable length restrictions as specified in [1] apply; if the Operator is not using VDSL (eg ADSL2+) then these length restrictions of the tie cable do not apply (although there is a length restriction if shared LLU is being deployed). Operators need to declare to OPENREACH whether or not they are using VDSL. Tie Cables will be provided as listed on the OPENREACH Price list at:-  
<http://www.openreach.co.uk/orpg/products/llu/lluhp.do>.

**FOR DETAILED TERMS AND CONDITIONS REFER TO THE SUB LOOP CIRCUIT ACCESS AGREEMENT**

- 2.4 In order to accommodate the relatively large number of additional cable terminations, OPENREACH may need to rebuild or replace the SLCP cabinet. The costs of this work will be borne by the Operator requesting access to that SLCP.
- 2.5 The service will be available nationally within areas covered by OPENREACH's network, subject to any technical limitations or special costs identified during the design stage or availability of supporting services.
- 2.6 All equipment connected to Sub Loop Circuits must comply with relevant specifications and with the Access Network Frequency Plan in force for the OPENREACH Network, to address interference issues. The ANFP [3] is published by NICC on their website (<http://www.nicc.org.uk>) and the latest issue of the ANFP will be shown on the 'Current Publications' page of the NICC website.
- 2.8 At the time of writing this document ANFP, Issue 3 (ND1602:2005/08) applies and is applicable to both full loop and sub-loop.
- 2.9 OPENREACH will remove pair gain devices from any purchased sub loop where doing so will not necessitate additional effort in excess of 50 man-hours or monetary equivalent in the OPENREACH Access Network. Other network intervention charges that may apply are itemised and listed on the OPENREACH Price list.
- 2.10 Charges for all SLU services are contained in the OPENREACH Carrier Price List at <http://www.openreach.co.uk/orpg/products/llu/lluhp.do>

**3. INFORMATION PROVISION FOR SLU**

- 3.1 Due to the lack of demand for this product no formal ordering process or forecasting exists, however this will be subject to review if this situation changes. Currently, any requests for SLU should will be made by the Operator on a per occasion basis via their Commercial Manager and the following interim manual process will apply:-
- 3.2 Until further notice the first stage will comprise of an Operator requesting from OPENREACH data for an MDF site. The data will contain a list of its SLCPs with their grid references, cable distance from the exchange, cable distance to the associated DPs and postcodes of the end customer's that they support. This information will normally be provided within 10 working days of the request being received by OPENREACH.
- 3.3 On receipt of instructions from the Operator to proceed and acceptance of the terms and conditions that apply the second stage (initial site survey) data will be provided on a per-SLCP basis. This information will allow an Operator to evaluate the service potential of the sub-loops available from the nominated SLCP. Provision of this information will necessitate an on-site survey coupled with additional research.
- 3.4 The initial survey will provide the following information:
  - Confirmed location of the SLCP: a descriptive address and a grid reference, as SLCPs do not have postal addresses with postcodes.
  - The CAL (Cabinet Assigned Loss) value (see ANFP [3] for details) for each SLCP.

**FOR DETAILED TERMS AND CONDITIONS REFER TO THE SUB LOOP CIRCUIT ACCESS AGREEMENT**

- If an Operator has declared that they propose to deploy VDSL, OPENREACH will specify the maximum length of the sub-loop tie cable that can be used based on the sub-loop tie cable specification [1] and any previous SLU deployments at those SLCPs using VDSL.
- An indication of spare capacity within the SLCP will indicate whether spare capacity exists for new pairs or, if limited capacity is available, the degree of SLCP enhancement or new build that will be required. OPENREACH will endeavour to provide such data to the Operator within 10 working days following the survey.

**Comment:** Does the 10 working days apply for all of the data listed in §3.4 or just this bullet point.

3.5 If the Operator wishes to proceed with a request following receipt of the initial survey data, a full joint survey will be required. This will provide a detailed investigation of the work and costs to uplift the SLCP and provide Sub Loop Tie Cables. This will be arranged within 5 working days of the request being made and should take place within 10 working days.

3.6 Proceeding with the SLU build at a particular SLCP will be conditional on the Operator formally accepting by email to their Commercial Manager the costs provided and terms and conditions offered by OPENREACH for SLU and any necessary permissions being approved by the relevant authorities. Normally OPENREACH will complete the build work within 55 working days from acceptance of the offer.

#### **4. LINE SHARING WITH SLU**

- 4.1 Line sharing with SLU will be only available to an Operator that has established an SLU presence at the relevant SLCP and entered into an agreement to provide a specific end user with service on the rented sub loop.
- 4.2 The low frequency service (e.g. analogue PSTN service) must be provided (and continue to be provided) to the end user from equipment providing dial tone in the MDF site to which the SLCP belongs.
- 4.3 Line sharing within the sub-loop service will be implemented on a dedicated point-to-point metallic path from a specific end user's premises, through the Operator's equipment, to the OPENREACH MDF site.
- 4.4 Implementing line sharing will require two pairs within the Sub Loop Tie Cable that link the Operator's accommodation to the SLCP. One line will carry the combined signal between the Operator and the end user and the other line will carry the low frequency service from the Operator back to the BT local exchange, via the SLCP.
- 4.5 The Operator must deploy their equipment and splitter within their SLU equipment enclosure.
- 4.6 The equipment deployed by the Operator must not interfere with the low frequency service spectrum used by OPENREACH, and must adhere to the requirements of the ANFP as per paragraph 2.8 and sub-loop tie cable specification [1].
- 4.7 The OPENREACH interface at the end user's premises will be a current PSTN NTE.

**FOR DETAILED TERMS AND CONDITIONS REFER TO THE SUB LOOP CIRCUIT ACCESS AGREEMENT**

**5 MPF (CLASSIC)**

- 5.1 MPFs within SLU will be only available to an Operator that has established an SLU presence at the relevant SLCP and entered into an agreement to provide a specific end user with service on the rented sub loop.
- 5.2 An MPF within the sub-loop service will be implemented on a dedicated point-to-point metallic path from a specific end user's premises, through the Operator's equipment, via the OPENREACH SLCP.
- 5.3 MPF (Classic) will require one pair within the Sub Loop Tie Cable that link the Operator's accommodation to the SLCP.
- 5.4 The equipment deployed by the Operator must adhere to the requirements of the ANFP as per paragraph 2.8 and sub-loop tie cable specification [1].
- 5.5 The OPENREACH interface at the end user's premises will be a current PSTN NTE.

**6 SUPPORTING PROCESSES - PROVISION**

- 6.1 Initially an Operator will sign the Sub-Loop Circuit Access Agreement and submit forecasts for SLCPs and Sub Loops.
- 6.2 Until further notice the Operator will submit electronically a request by email to their Commercial Manager for initial data as described in 3.2 above. OPENREACH will endeavour to return results within 10 Working days. Once the data has been provided to the Operator, the Operator must decide whether to proceed.
- 6.3 If the Operator wishes to progress further with a particular SLCP, the Operator will submit an email to their Commercial Manager to requesting a first stage survey as in 3.3 above.
- 6.4 An Operator should confirm within 10 working days by email to their Commercial Manager if they wish to progress to a full joint survey, failure to do so will be regarded by OPENREACH as an Operators intention to take no further action and charges for the initial survey will apply.
- 6.5 A full survey will provide detailed plans and charges for provision of the Sub Loop Tie Cables, SLCP Uplifts and any civils work required for that SLCP, this will be regarded by OPENREACH as a Sub Loop Offer.
- 6.6 Should the Operator commit to proceeding further with SLU, the next stage will be for the Operator to accept the Offer for connection at the SLCP within 10 working days; OPENREACH to perform the work (undertake SLCP rebuild works, provide the sub-loop tie cable and install the handover box to the plan identified at the full survey stage. OPENREACH will endeavour to complete this work within 55 working days of receipt of order subject to activities within its reasonable control.
- 6.7 The Operator will be responsible for providing their accommodation at a suitable location and connecting it to their network and power supplies. The Operator will need to provide network access from the handover box into their equipment enclosure for the tie cable(s).

**FOR DETAILED TERMS AND CONDITIONS REFER TO THE SUB LOOP CIRCUIT ACCESS AGREEMENT**

- 6.8 Following completion of the SLCP uplift work, provision of the Sub Loop Tie Cable the Operator may offer services to any end user that is served by the chosen SLCP.
- 6.9 The Operator will submit a pre-order enquiry for a Sub Loop Circuit or a Shared Line Facility. OPENREACH will acknowledge this request and within 5 working days provide details of the line characteristics for that sub loop, this will be the estimated line length.
- 6.10 If following receipt of the line characteristics data the Operator wishes to proceed with the sub loop order, the operator will submit a confirmed order to OPENREACH within 10 working days. OPENREACH will use reasonable endeavours to provide the line within 5 working days, taking account of any 'statutory cooling off' or retail contract termination periods. If pair gain devices or other electronics need to be removed from the line to provide the service, the timescales may be in excess of 5 working days.
- 6.11 All equipment deployed by the Operator for use with the aforementioned sub-loops must have previously been tested to ensure that it conforms to the ANFP [3] and is configured to conform to the specified Cabinet Assigned Loss value for the SLCP at which it is to be deployed.
- 6.12 The additional conditions applying to Line Sharing :- the Operator will be responsible for installing a splitter and DSLAM that conform to the specification in the Sub Loop Unbundling Line Sharing Splitter specification [2] in order to protect the low frequency service.

**7 SUPPORTING PROCESSES - REPAIR**

- 7.1 End users will report all MPF faults to the SLU Operator. The only exception to this will be where the end user has a low frequency service (e.g. PSTN) fault and a Shared Line Facility agreement is in place.
- 7.2 The Operator must prove the fault off their network and CPE before raising the fault with OPENREACH.
- 7.3 OPENREACH will be responsible for repairing any faults that occur on the metallic sub-loop path between the NTE at the end user's premises and the Operator's Interface Point. OPENREACH will also be responsible for repairing faults that occur on the low frequency (e.g. PSTN) service from the BT exchange MDF site.
- 7.4 OPENREACH will provide a 2 stage fault reporting process for fault reports received from the Operator. This will mirror the fault reporting procedure in operation under Full Local Loop Unbundling. Faults found at Stage 1 will not be charged for separately, however, fault reports, which are found to be RWT following investigation, will be charged, this will also apply to stage 2 fault investigations that prove RWT. It should be noted that stage 1 repair only applies to SMPF and is not available for full MPF's where stage 2 will only be possible. Stage 2 only will also apply for both SMPF and full MPF's at fibre fed SLCPs.
- 7.5 OPENREACH will endeavour to respond to a fault on the metallic paths for which it has responsibility within within the timescales of the carepackage applicable.
- 7.6 OPENREACH is not responsible for repair of faults relating to the Operator's terminating equipment.
- 7.7 Some repair activity on a line will be intrusive on the Operator's service provisions.

**FOR DETAILED TERMS AND CONDITIONS REFER TO THE SUB LOOP CIRCUIT ACCESS AGREEMENT**

**8 PRODUCT AVAILABILITY**

8.1 The SLU will be available at any SLCP within the OPENREACH Access Network with the following exceptions:

- Where the SLCP is scheduled for removal within the next 3 years at the time of application.
- The SLCP is already scheduled for major works.
- Previous SLU requests have resulted in the SLCP being extended to the maximum practical capacity and there is insufficient space.
- Where the end customer is not served by means of metallic paths
- Where no spare metallic pairs exist between the relevant SLCP and the end customer
- Where the deployment (either planned or actual) of addition electronic equipment on an SLCP will compromise network integrity.

8.2 The parts of OPENREACH's Access Network that are not serviced by a SLCP will not be available to SLU. Where lines are connected directly to the exchange a service equivalent to SLU will be available through Full LLU.

8.3 Within an SLU arrangement the Operator will only be able to access end users that are already connected to the designated SLCP with a metallic path. End users cannot be transferred from other SLCPs.

8.4 The SLU Shared Line Facility service will be available at any location that has been made available to SLU and tie cables have been allocated for the line share facility.

**REFERENCES**

1. Specification for the Sub Loop Access Tie Cable, Issue 3
2. Exchange based Splitter Specification for the use with Local Loop Unbundling Line Shared Service – ND1606:2005/01 (available at <http://www.openreach.co.uk/orpg/products/llu/lluhp.do>)
3. Specification of the Access Network Frequency Plan (ANFP) for transmission systems used on the OPENREACH access network – ND1602:2005/11 (available at <http://www.nicc.org.uk>)

**ABBREVIATIONS**

ANFP	Access Network Frequency Plan
CAL	Cabinet Assigned Loss (see reference [3] for details)
MPF	Metallic Path Facility
NICC	Network Interoperability Consultative Committee
NTE	Network Termination Equipment
SLCP	Sub-loop Connection Point
SLU	Sub-loop Unbundling

**END**